

MOBO-C50

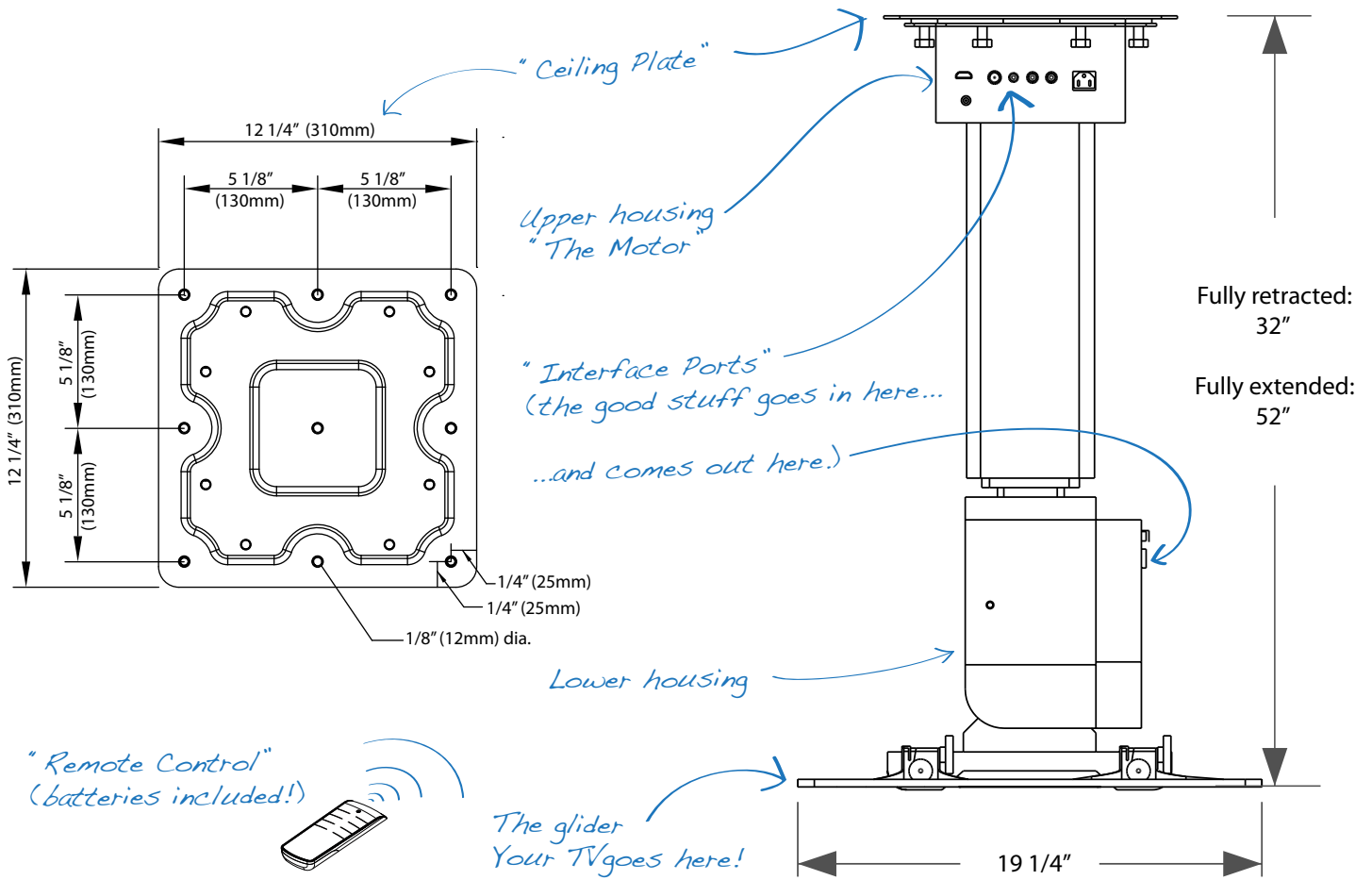







Motorized Flat Screen TV Ceiling Mount

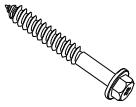





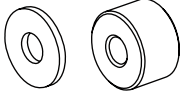





Parts:

Please make sure you have all parts before beginning installation. If any parts are missing or damaged, contact your retailer and DO NOT ATTEMPT INSTALLATION. Use only parts provided by the manufacturer or damage may result.

<p>① Wood screws 9 pcs</p> 	<p>② Concrete anchoring bolt 9 pcs</p> 	<p>③ M6 x 15mm Bracket bolt 4 pcs</p> 	<p>④ M6 Bracket nut 4 pcs</p> 
<p>⑤ M6 x 15mm Television screw 4 pcs</p> 	<p>⑥ M5 x 15mm TV screw 4 pcs</p> 	<p>⑦ Washer and Spacer 4 pcs each</p> 	<p>⑧ Power adapter 1 pc</p> 

Tools:

The following tools are necessary for proper installation. If you don't own them already, you could borrow them from your neighbor. But if your neighbor is like ours, it's better to just go buy them.

<p>pencil</p> 	<p>stud-finder</p> 	<p>3/16" drill bit</p> 	<p>13/32" masonry drill bit</p> 	<p>power drill</p> 	<p>hammer</p> 	<p>socket wrench</p> <p>10MM</p> 	<p>Phillips screw driver</p> 
---	--	--	---	--	---	--	--

SAFETY NOTICES

The television and bracket are heavy and must be attached securely to a wall or ceiling that is strong enough to support them both. Attaching to drywall is not advised. If you are not familiar with how your walls or ceilings are constructed, you should seek the advice of an expert. The manufacturer and retailer DO NOT assume any liability for improper installations or misuse. So if your television falls off the wall, it is entirely your own problem.

DANGER!

This motorized bracket is an electrical device. This unit is designed for indoor use only. You should only use it in a dry and clean environment, and plugged into a properly grounded electrical outlet. If you die of electrocution, you will not be able to enjoy your television.

To reduce the risk of electrical shock you should take some basic precautions, including:

1. Always unplug the unit when installing, removing, mounting, adjusting, or cleaning the unit.
2. Never operate the unit outside of the limits, specifications or parameters described in this booklet.
3. Do not attach anything else to the bracket other than a television of the specified size/weight.
4. Do not attach any other accessories or devices, and do not let anyone touch the unit while in operation.
5. Never operate the system if it has become wet; if it shows any signs of damage; if it has become clogged with dust, lint or hair; shows signs of excessive wear and tear; or, if the power cords have become damaged or frayed.
6. Keep the unit and power cords away from heat sources such as vents, heaters, fireplaces, or radiators.
7. Use only a dry cloth to clean the unit; do not use any chemicals, sprays or liquids of any kind.
8. Periodically check to make sure all screws and fastening devices are properly tightened and secure. To avoid damage to the screw threads be sure not to over-tighten.

WARNING!!!

This unit is designed for **PROFESSIONAL INSTALLATION**. If you attempt installation yourself, you assume all risks and consequences, so please be sure that you know what you're doing. If your spouse says, "Don't worry, I know what I'm doing," you should probably still worry. Incorrect installation can result in personal injury, and damage to your television or other property.

The manufacturer and retailer are **NOT** responsible for improper installations.

The limited warranty only covers defects in the design or manufacture of the bracket, and doesn't cover issues arising from improper installation or misuse. If you are uncertain about how to safely install this unit, please seek help from a professional installer. These instructions are based upon a typical installation scenario; your particular circumstances may require special arrangements that are outside the scope of these instructions and should be undertaken only by a trained professional.



Installation Instructions:

We strongly recommend that this unit be installed only in consultation with a professional installer.

WARNING: Do NOT attempt to operate the unit until it has been installed in a fully vertical position; plugging in the unit before full installation will damage the unit and void your warranty.



Step 1. Determine Ceiling Type (Wood or Concrete)



Before you begin, you must make sure your chosen installation location can support the weight of both the bracket and the television.

Typically this will require you to screw directly into wood joists/braces or into a solid masonry ceiling surface.

If you are uncertain whether your desired location can support the weight, consult an expert before attempting.

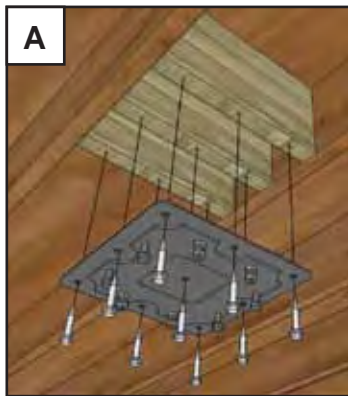

Step 2. (A) Mount Ceiling Plate - Wood

The support beams should have sufficient supports already installed. Consult a professional contractor to determine proper positioning and alignment.

Remove the ceiling plate from the upper motor housing and use it to mark the location of the screw holes. Use a power drill with a 3/16" bit to drill starter holes in the studs. Mount the ceiling plate to the studs using the eight wood screws (discard the plastic screw sleeves if any).

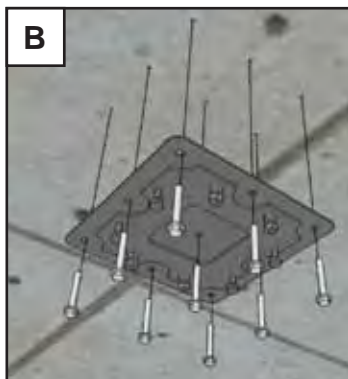

Step 2. (B) Mount Ceiling Plate - Concrete

Ensure the ceiling thickness is at least 3 1/4 inches and that there are no materials such as rebar or steel plates, etc., in the mounting location.

Loosen the ceiling plate from the upper motor housing and use it to mark the location of the screw holes. Use a power drill with a 13/32" masonry bit and drill the holes in the marked locations to a depth of approx 2 3/4 inches. Mount ceiling plate using the eight concrete anchoring bolts.



Step 3. Join Motor Housing to Ceiling Plate (2 people required)

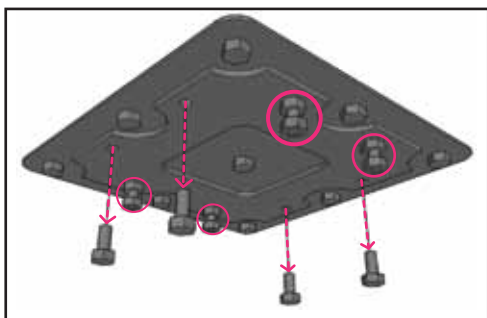

CAUTION!
 At least two people are required to safely lift the ceiling mount!



Remove the four bolts as indicated and slightly loosen the second nut on each of the dual-nut bolts so that there is at least a 1/4" gap between the two.

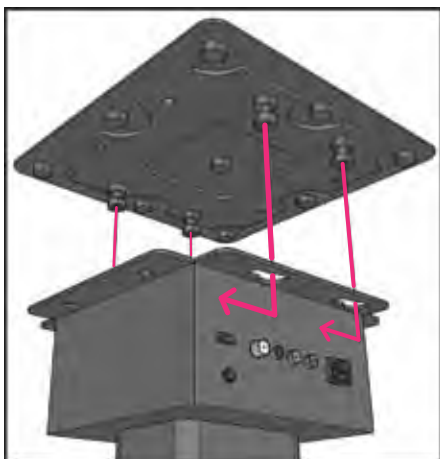

Using two people, lift the unit to the ceiling plate and insert the loosened nuts through the keyhole, sliding to hold unit in place.



While continuing to brace the unit in place, tighten each of the second nuts and replace the four remaining bolts to secure the unit.

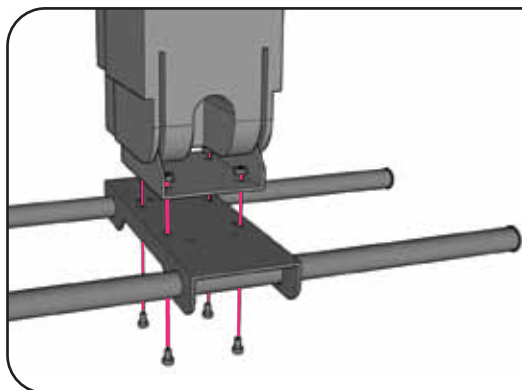
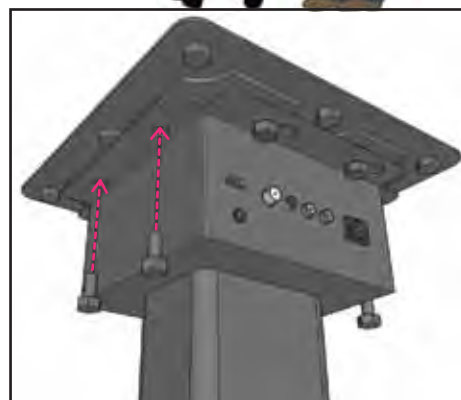

Step 4. Attach Bracket Rail Assembly

The bracket rails are installed in the factory but may need to be adjusted to ensure the rails are centered by loosening the locking screws. Install the entire bracket to the lower motor housing using 4 bracket screws (③) and 4 nuts (④).

Step 5. Attach Bracket Arms to Television

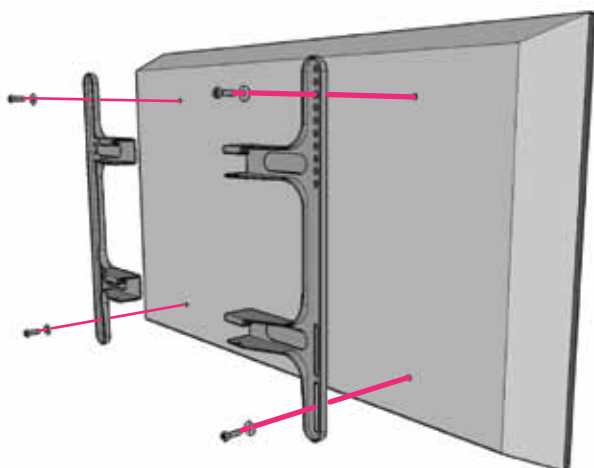

Locate and align the TV mounting holes with the bracket. Use the television screws (⑤ or ⑥) along with the washers and spacers (⑦) and tighten gently.

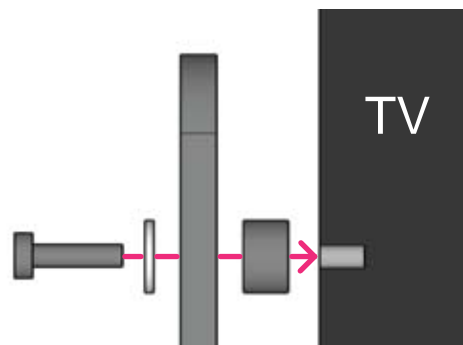

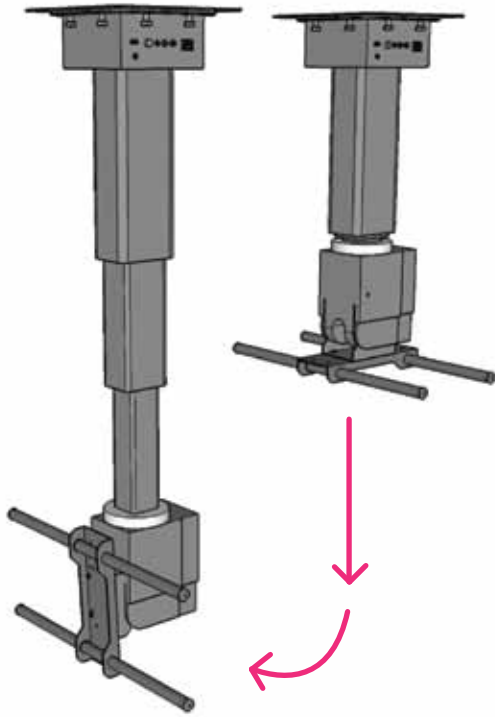

Step 6. Attach power cord and AV cables to upper housing

Now it is safe to test the function of the mounting arm. Use the remote (see Operating Instructions) to lower mount to its fully extended position and to ensure the rail bracket is in its vertical position.

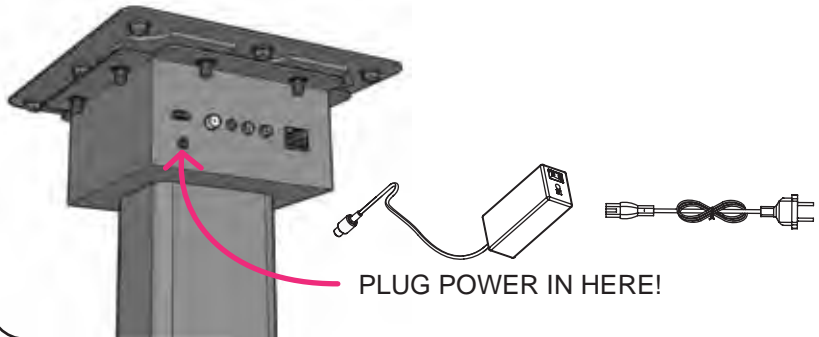

CAUTION!

Never attempt to manually extend or retract the arm. Attempting to do so will damage the unit and void the warranty.

Step 7. Place Television on Rails (2 people required)

First remove the locking blocks and hand screws if in place. Carefully place the television on rails and check to make sure it is properly seated in the bracket channels. Someone must brace the television until the locking blocks are secure.

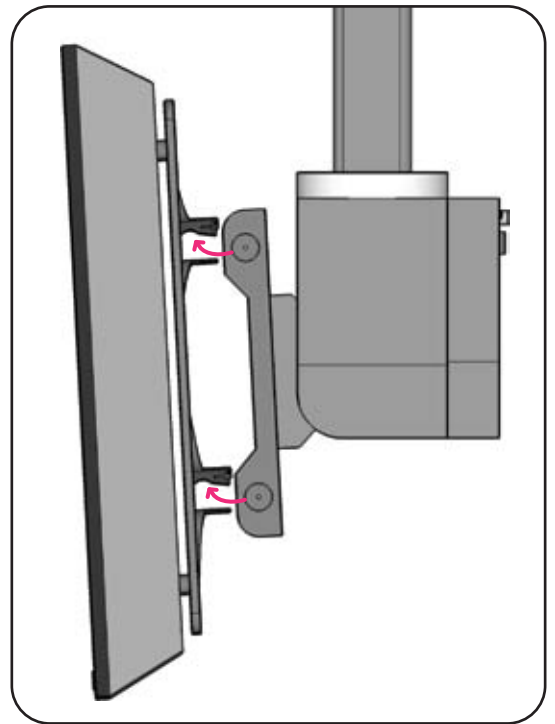

Step 8. Secure Locking Blocks and Handscrews

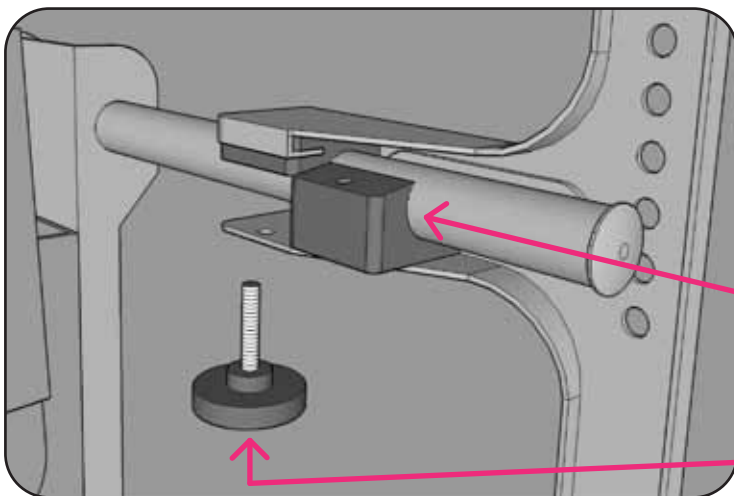

*CAUTION!
All four locking blocks must be properly installed before attempting operation.*

Slide the Locking Blocks into place.

Tighten the Locking Handscrews.

Operation Instructions:

Step 9. Attach AV and Power

Attach AV and power cables from your sources to the interface ports at the top of the unit. **DO NOT ATTACH** source cables directly to the TV; **ONLY** attach the TV inputs to the interface ports at the bottom of the extension arm. Make sure to use short cables to avoid snagging.

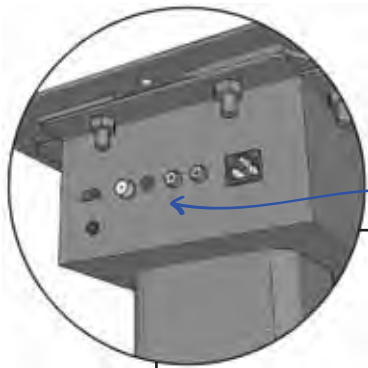

from AV sources

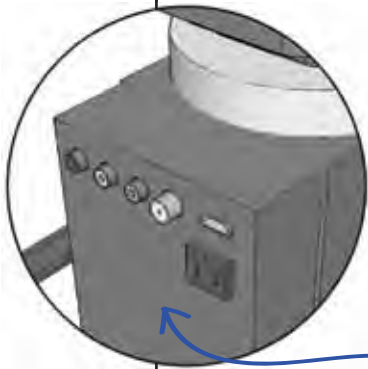

35°

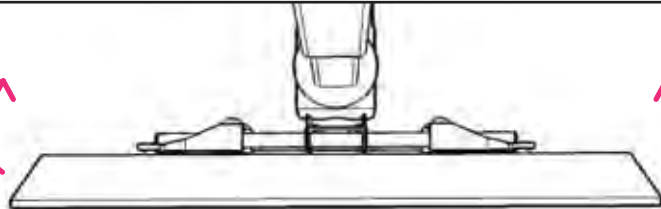

35°

Step 10. Remote Control

Install battery (included) and test operation of the mount.

Left/right rotation: 35° in each direction (from vertical center)

Tilt: 0° to 87° (from horizontal)

Extension: 40" (1000mm) (from retracted position)

to television



↻ : hold down and turns the TV clockwise

↺ : hold down and turns the TV counter-clockwise

↑ : hold down and tilts the TV up

↓ : hold down and tilts the TV down

Ⓞ : one click to fully extend the ceiling mount and tilt TV to vertical

Ⓞ : one click to fully retract the ceiling mount and tilt TV to horizontal

87°

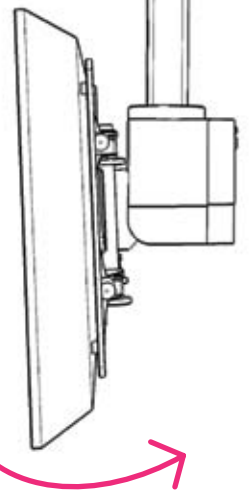

CAUTION!

Please ensure that the area around the television is free from any obstructions that might prevent free movement of the unit, otherwise you may damage the television or motor.

Also make sure that your AV and power cabling are installed so that movement of the television does not cause snagging or damage to your cables or connectors.

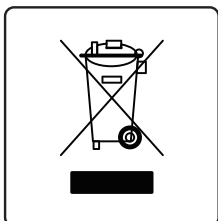

This device contains electronics and other materials which should only be disposed of in a proper disposal facility designed to process electronic waste.

Please help protect our environment:
DO NOT dispose of this unit in household or office trash.



Specifications:

General Specs:

Product Dimension (inch)	Carton Dimension (inch)	Net Weight (lbs.)	Gross Weight (lbs.)
32 x 23 $\frac{7}{8}$ x 19 $\frac{1}{4}$	35 x 14 x 12	63 ± 1	68 ± 1

Electrical Specs:

Rated Voltage	Current (no load)	Current (rated load)	Operation Temperature	Maximum Humidity
DC24V	≤ 0.5A	≤ 2A	-20°C to 50°C	80% RH

Operational Specs:

TV Size	Maximum Install Pattern	Minimum Install Pattern	Maximum Bearing Weight	Swivel Angle	Tilt Angle
32" - 65"	860 x 460(mm)	185 x 135 (mm)	110 lbs.	±35°	Down: 87°

Certifications:

 Pending	 Approved	 Approved	 Approved
<p>This device complies with part 15 of the FCC Rules. Operation is subject to the following two conditions: (1) this device may not cause harmful interference, and (2) this device must accept any interference received, including interference that may cause undesired operation.</p>			

Warranty:

ONE YEAR LIMITED WARRANTY

PLD STUDIOS LLC (hereinafter, "PLD") warrants to original end-users of PLD products that those products will be free from defects in materials and workmanship, under normal use, for a period of one year from the date of purchase by the original end-user. At its option, PLD will repair or replace, or refund the purchase price of, any product that fails during the term of this warranty.

Any implied warranties which may apply are limited in duration to a period of one year from the date of purchase by the original end-user. Notwithstanding the foregoing, PLD specifically disclaims any and all implied warranties, including, without limitation, implied warranties of merchantability and implied warranties of fitness for a particular purpose, with respect to products used for commercial purposes. Some states do not allow limitations on how long an implied warranty lasts, so the above limitation may not apply to you.

This warranty does not cover damage caused by (a) service or repairs by anyone other than PLD or its authorized repair personnel, (b) the failure to utilize proper packing when returning the product, (c) improper installation or the failure to follow the instructions or warnings provided by PLD, or (d) misuse or accident, in transit or otherwise.

In no event shall PLD be liable for incidental or consequential damages or damages arising from the use of, or the inability to use, the product, or criminal or tortious acts by any third party. Some states do not allow the exclusion or limitation of incidental or consequential damages, so the above limitation or exclusion may not apply to you.

This warranty is in lieu of all other warranties, expressed or implied, and is the sole remedy with respect to product defects. No dealer, distributor, installer or other person or organization is authorized to modify or extend this Limited Warranty or impose any obligation on PLD, its resellers or distributors, in connection with the sale of any PLD product.

This warranty gives specific legal rights, and you may also have other rights which vary from state to state.

To ask any questions or to obtain service under this warranty, please contact PLD at 415-992-6620, or contact support@pldstudios.com to describe the nature of the warranty issue and to obtain a Return Material Authorization (RMA) number with instructions for returning the product to PLD. Under no circumstances will PLD accept any returned product without a previously-issued "Return Materials Authorization" number.